

VeneerPro-VB

Simple and reliable single Blade V Belt Saw.
Corners can be cut by processing the Stone with one additional Pass.

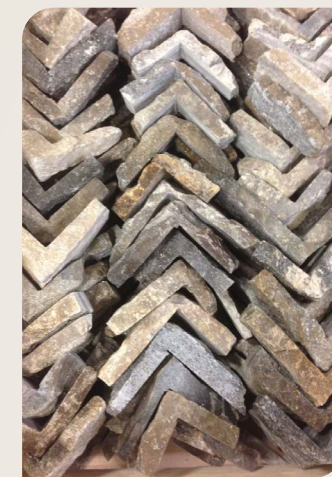

VeneerPro -VB Technical specifications	Imperial	Metric
Arbor driven motor	50 HP	50 HP
Required power	75amps, 3 phase ,480 V	75amps, 3 phase ,400 V
Arbor diameter	3.25"	82.55 mm
Blade diameter	40" - 48"	1 - 1.2 meter
Maximum cutting depth	16"	400 mm
Variable conveyor speed	0-10 ft/min	0 - 3 meter/min
Standard spindle rpm	430	430
*Subject to customer request		
Return conveyor speed	10.5'/min	3 meter/min
Return conveyor length	16.5'	5 meter
Basic amp control		
Machine body	Galvanized	Galvanized
Blade cover	Stainless steel	Stainless steel
Water consumption	16 galon/min	60 liter/min
Total weight approximately	8,800 lbs	4 MT
Optional		
Inverter for variable arbor rpm		

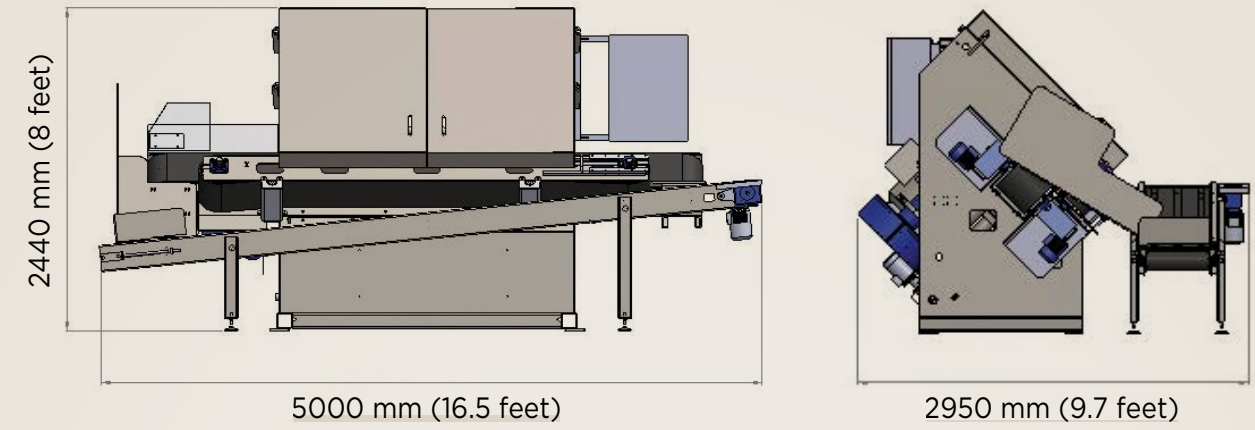