

# MultiPro-Edge48

## Up to 16 Blades!

Ledge/Stack Stones, Ashlar, Pavers,  
Tiles, Baseboards, Cobblestones...

**Option:** 32"(800mm) Blades with 215hp motor.

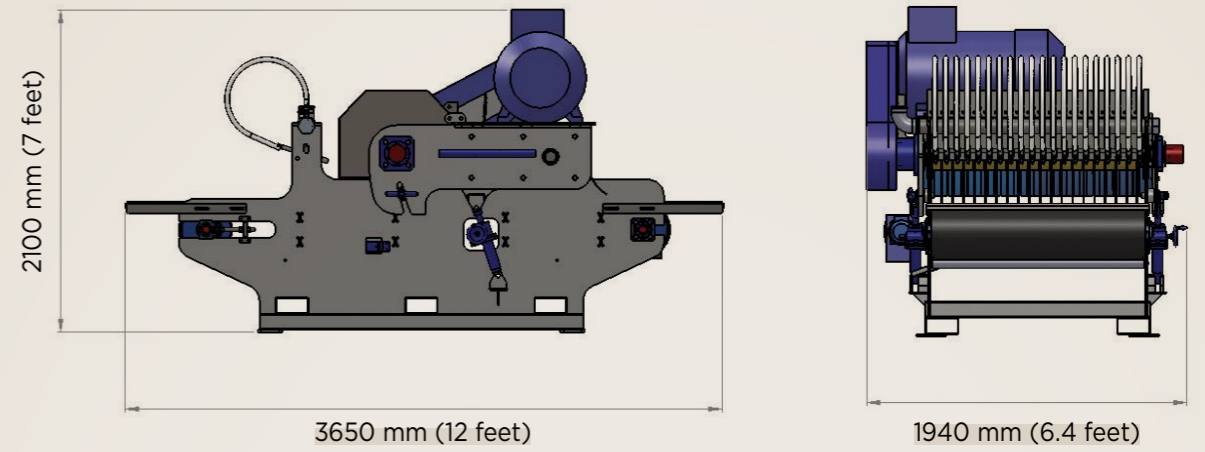
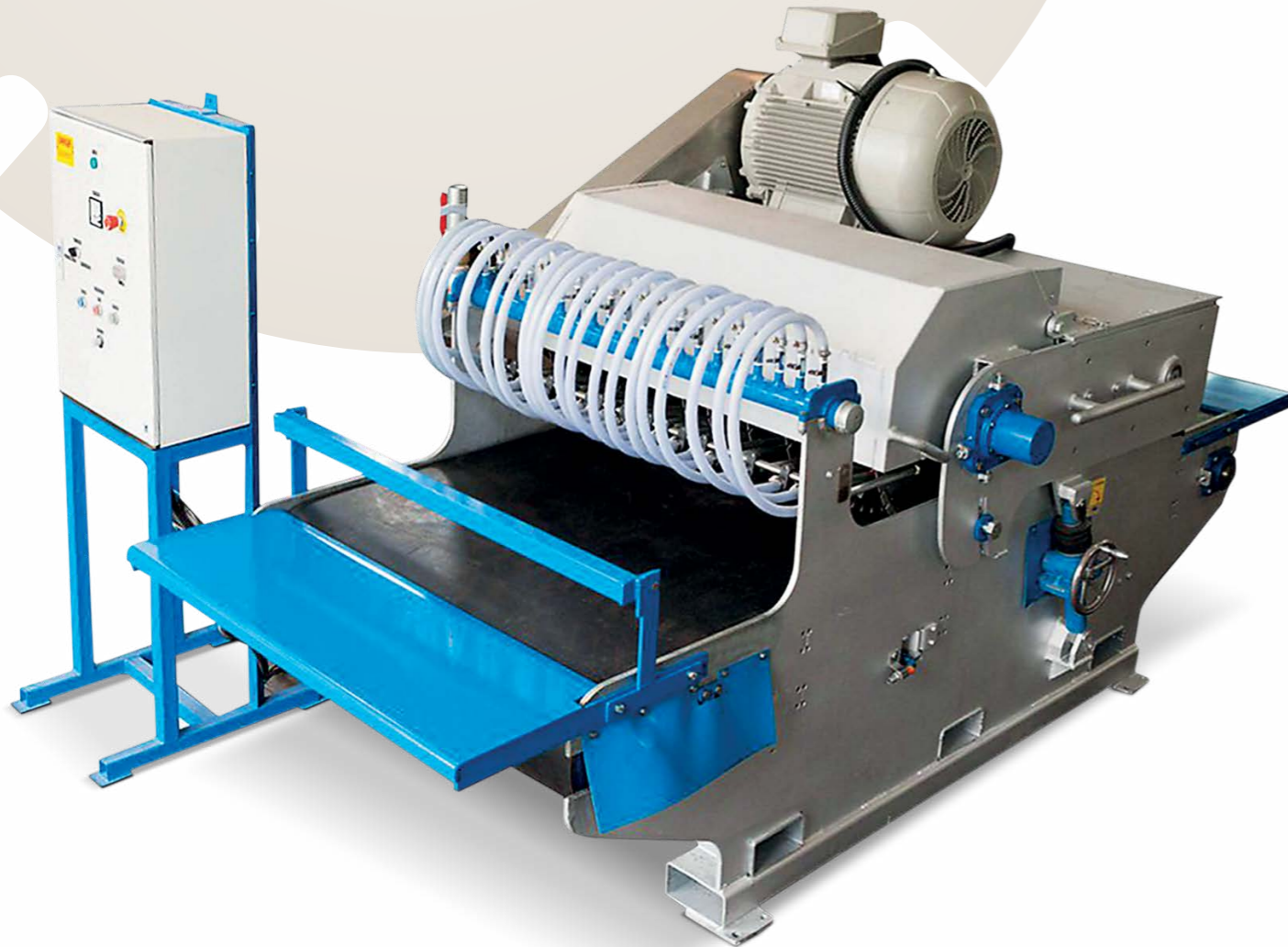

MultiPro-Edge48 Technical specifications	Imperial	Metric
Arbor driven motor	100 HP	100 HP
Required power	135amps, 3 phase, 480 V	135amps, 3 phase, 400 V
Arbor diameter	3.94"	100 mm
Blade diameter	20" - 24"	500mm - 600 mm
Max cutting depth	6"	150 mm
Max stone width	48"	1200 mm
Variable conveyor speed	0 - 7 ft/min	0 - 2.1 meter/minute
Possible blades per spindle	16	16
Standard Spindle RPM	800	800
*Subject to customer request		
Basic amp control		
Machine body	Galvanized	Galvanized
Blade cover	Stainless steel	Stainless steel
Water consumption	7 gallon/min - per blade	27 liter/min - per blade
Total weight approximately	11,000 lbs	5 MT

