

# MultiPro

Ledge/Stack Stones, Ashlar, Pavers, Tiles, Baseboards, Cobblestones...

**Option:** 32" (800mm) Blades.

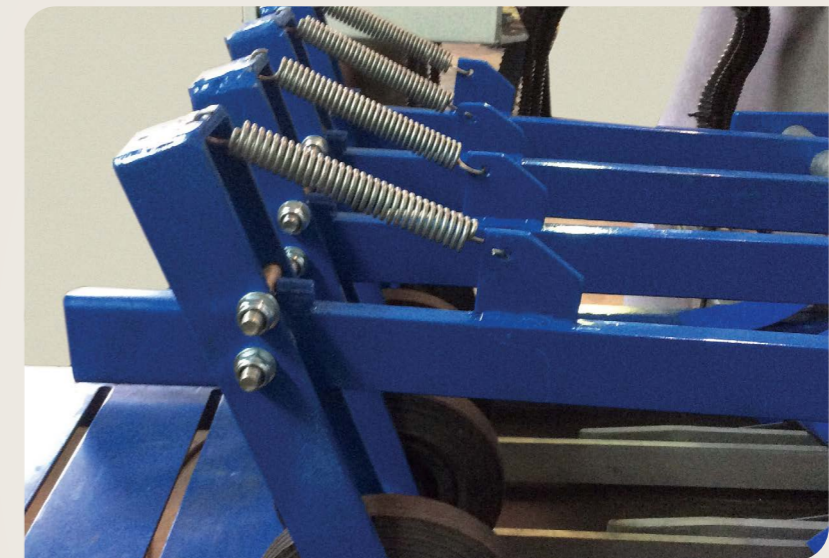
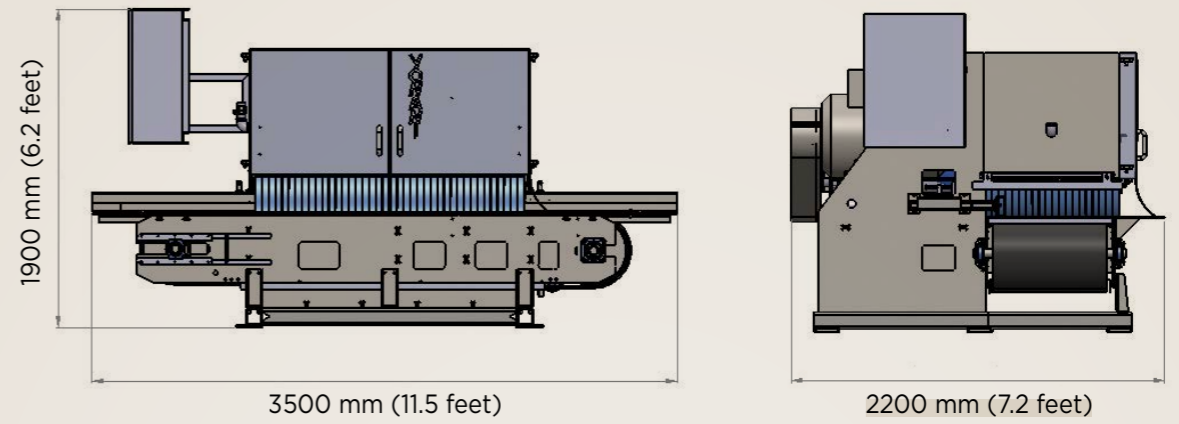

MultiPro Technical specifications	Imperial	Metric
Arbor driven motor	75 HP	75 HP
Required power	100amps, 3 phase, 480 V	100amps, 3 phase, 400 V
Arbor diameter	3.15"	80 mm
Blade diameter	20" - 24"	500 mm - 600 mm
Max cutting depth	8"	200 mm
Max stone width	24"	600 mm
Variable conveyor speed	0 - 7 ft/min	0 - 2.1 meter/minute
Possible blades per spindle	10	10
Standard spindle rpm	800	800
*Subject to customer request		
Basic amp control		
Machine body	Galvanized	Galvanized
Blade cover	Stainless steel	Stainless steel
Water consumption	3 gallon/min - per blade	12 liter min - per blade
Total weight approximately	10,000 lbs	4.5 MT

