

CornerPro

High accuracy and efficiency by cutting corners in one pass.

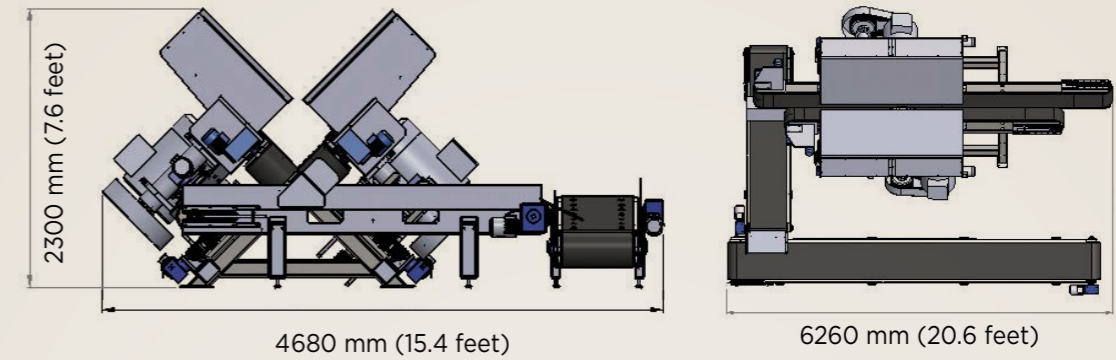

CornerPro Technical specifications	Imperial	Metric
Two arbor driven motors	50 HP	50 HP
Required power	150amps, 3 phase ,480 V	150amps, 3 phase ,400 V
Arbor diameter	3.25"	82.55 mm
Main blade diameter	40" ~ 48"	1 - 1.2 meter
Corner blade diameter	40"	1000 mm
Maximum cutting depth	16"	400 mm
Variable conveyor speed	0 -10 ft/min	0-3 meter/min
Standard spindle rpm	430	430
*Subject to customer request		
Return conveyor speed	10.5'/min	3 meter/min
Return conveyor length	16.5'	5 meter
Short return conveyor length	6'	1.8 meter
Basic amp control		
Machine body	Galvanized	Galvanized
Blade cover	Stainless steel	Stainless steel
Water consumption	32 galon/min	120 liter/min
Total weight approximately	11,000 lbs	5 MT
Optional		
Inverter for variable arbor rpm		

