

MultiPro-400XL

Options:

- 32" (800mm) Blades
- Brick corner cutting unit
- Tile squaring device

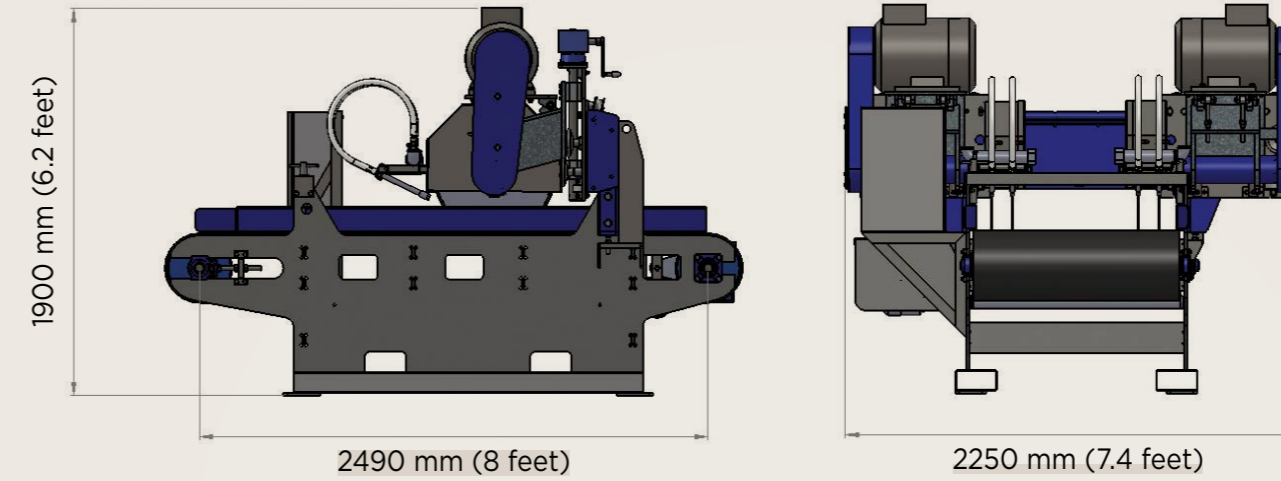

Brick corner cutting unit



Tile squaring device



MultiPro-400XL Technical Specifications	Imperial	Metric
Two Arbor Driven motors	30 HP	30 HP
Required power	90amps, 3 phase, 480 V	90amps, 3 phase, 400 V
Arbor Diameter	2.36"	60 mm
Blade diameter	24" - 28"	600 mm - 700 mm
Max cutting depth	10"	250 mm
Max stone width	40"	1 meter
Variable conveyor speed	0 - 7 ft /min	0 - 2.1 meter/ minute
Possible Blades per Spindle	2	2
*Standard Spindle RPM	800	800
*Subjected to customer request		
Machine body	Galvanized	Galvanized
Blade Cover	Stainless Steel	Stainless Steel
water consumption	3 galon/ min - per blade	12 liter / min - per blade
Total weight approximately	8,800 lbs	4 MT