

VeneerPro-VB

Simple and reliable single Blade V Belt Saw. Corners can be cut by processing the Stone with one additional Pass.

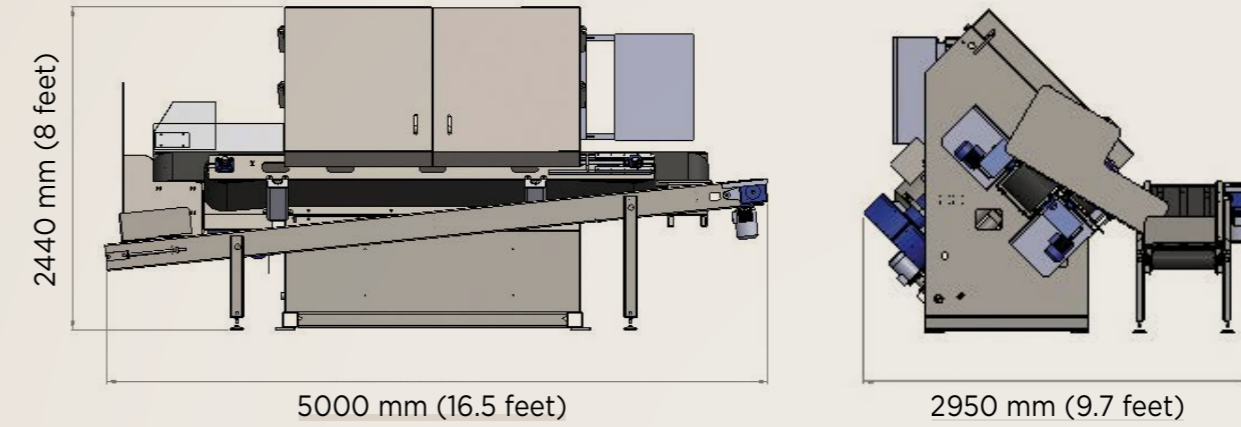

VeneerPro -VB Technical Specifications	Imperial	Metric
Arbor Driven motor	50 HP	50 HP
Required power	75amps, 3 phase ,480 V	75amps, 3 phase ,400 V
Arbor Diameter	3.25"	82.55 mm
Blade diameter	40" - 48"	1 - 1.2 meter
Maximum Cutting Depth	18"	450 mm
Variable conveyor speed	0-10 ft /min	0 - 3 meter/min
*Standard Spindle RPM	430	430
*Subjected to customer request		
Return Conveyor Speed	10.5' /min	3 meter/min
Return Conveyor Length	16.5'	5 meter
Machine body	Galvanized	Galvanized
Blade Cover	Stainless Steel	Stainless Steel
water consumption	16 galon / min	60 liter / min
Total weight approximately	8,800 lbs	4 MT
Optional		
Inverter for variable arbor RPM		
PLC with AMP Control		